

THERMAHYBRID AWNING WINDOWS

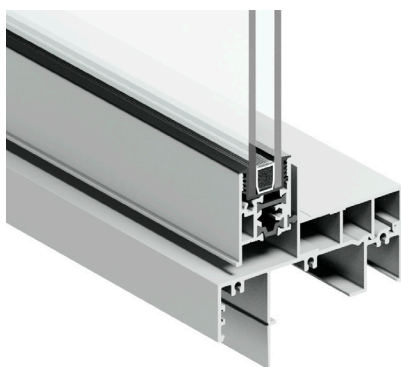

Trend's ThermoHybrid series is our latest innovation to support a cost efficient, practical, and seamless transition to the new 7-star requirements. Achieve improved energy performance without the expense of a fully thermally broken suite.



- The ThermoHybrid series merges thermally broken technology with Trend's aluminium range for exceptional energy performance.
- Achieve a U Value as low as 3.4 in a bold semi-commercial suite, without going to the expense of a fully thermally broken suite.
- Robust bold frame complements our existing aluminium series and features the Quantum architectural frame and the minimal sash aesthetics of the Synergy awning window.
- Maintain a cohesive look across the build while upgrading locations to meet the performance requirements.
- Don't compromise on your vision – meet and exceed performance standards without reducing window sizes.
- No modifications needed to your building process. The same build-in method as our Aluminium series.
- Available in the same sizes and variety of configurations and coupling options that you enjoy today.
- Chain winder features an integrated lock-and-handle in one. The stainless-steel chain offers durability and reliability.
- Keyed alike to other Trend windows. Use one key for multiple windows.
- Restricted opening option to prevent falls.
- Double-glazing as standard, prevents heat transfer between inside and outside, reduces energy bills and offers year-round comfort.
- Designed, tested, and manufactured in Australia for local conditions, ensuring a compliant, high-performance product with exceptional reliability. Backed by a 10-year warranty.

Energy efficient

The thermally broken aluminium sash prevents heat transfer, improves energy efficiency, and offer low maintenance and durability.

ARCHITECTURAL THERMAHYBRID AWNING WINDOWS

Specifications

Product	Architectural Awning Windows
Product series	ThermaHybrid
Frame profile	102mm x 25mm
Sill options	Standard Sump sill
Max frame	6400mm high or 6400mm wide
Max sash	Available options: 610mm high x 2400mm wide 1340mm high x 1210mm wide 2110mm high x 922mm wide Max weight 40kgs
Sash profile	Stiles 42mm, rails 42mm
Glazing	20mm Double glazing only
BAL rating	Deemed to satisfy BAL29
Seal type	Bulb seal
Colour options	Ultra Black, Pearl White, Surfmist and Monument
Screen options	Flyscreen and security screens
Hardware options	Chain winder – Black, White, Monument and Silver
Installation options	By builder
Warranty	10-year warranty

For full range of configurations and standard sizes refer to the standard size and range charts.

Performance

Wind and water performance	
Performance criteria	Rating
SLS	800Pa
ULS	2000Pa
Water	200Pa
N rating	N3 Corner/N4
Thermal performance	
Performance criteria	Rating
Double glazed Uw range	3.4 - 4.4
Double glazed SHGC range	0.26 - 0.56



Bold architectural aesthetic

Achieves larger window sizes and complements the aesthetic as our Quantum aluminium series.

ARCHITECTURAL
**THERMAHYBRID
AWNING WINDOWS**

Hardware



Chain winder